

Name: _____ Date: _____

ARTIFICIAL GRAVITY

What You Need

2 paper plates	1 ruler
1 large bead	1 stick
1 scissors	8 pieces of tape

What You Do

1. First, build your space station. Mark the centre of both paper plates. Poke a hole with the stick through the centre of each plate.
2. Mark a circle on one paper plate about one inch from the edge. Also, draw two lines through the middle of the plate about two cm apart as shown in Figure 1.

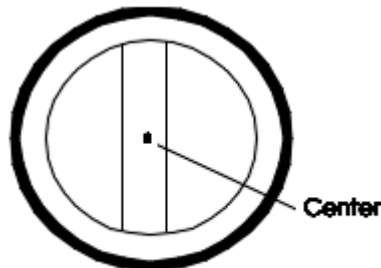

Figure 1

3. Cut out the shaded areas shown above in Figure 2 on just one plate.

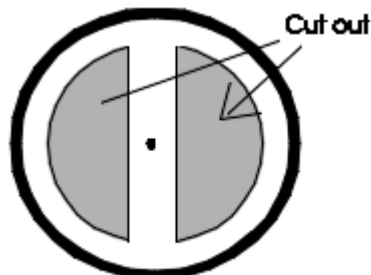

Figure 2

4. Put one paper plate upside down on top of the other plate. Tape the edges together in eight places as shown in Figure 3.

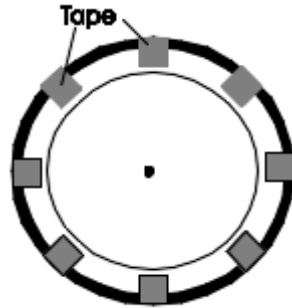

Figure 3

5. Put the stick through the two holes in the centre and practice spinning your space station while your partner holds the stick.
6. Hold your space station so the cut open part of it is facing up. Put the bead in near the middle. We will pretend the bead is an astronaut.

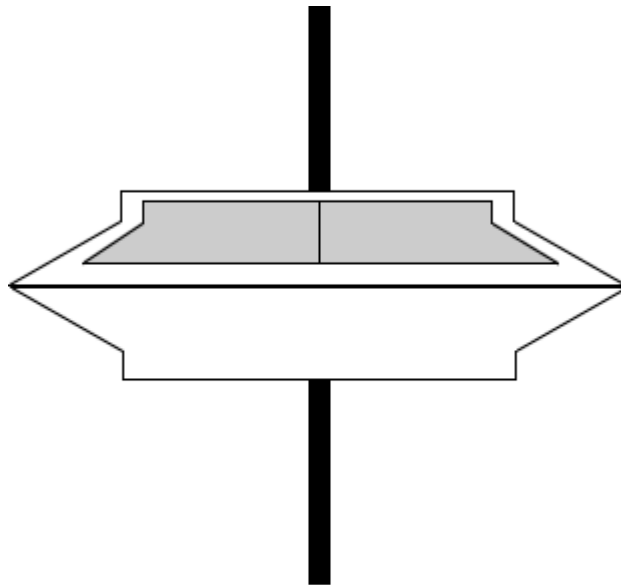

Figure 4

7. Spin your space station and write down what happens to the astronaut. (If the astronaut falls out, put her or him back in and try again. Try spinning a little slower.)

8. What do you think will happen to the astronaut if you tip the space station like in Figure 5 while it is spinning?

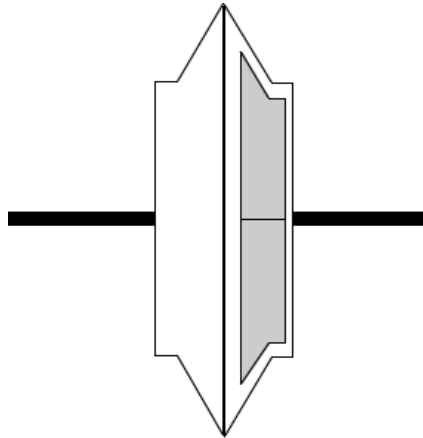

Figure 5

9. Try spinning the space station again. While one partner keeps the space station spinning, the other partner should tip the stick. What happens to the astronaut?

Think About It

When the space station was spinning, we created artificial gravity that kept the astronaut from falling out. Which direction is "down" for your astronaut?
