

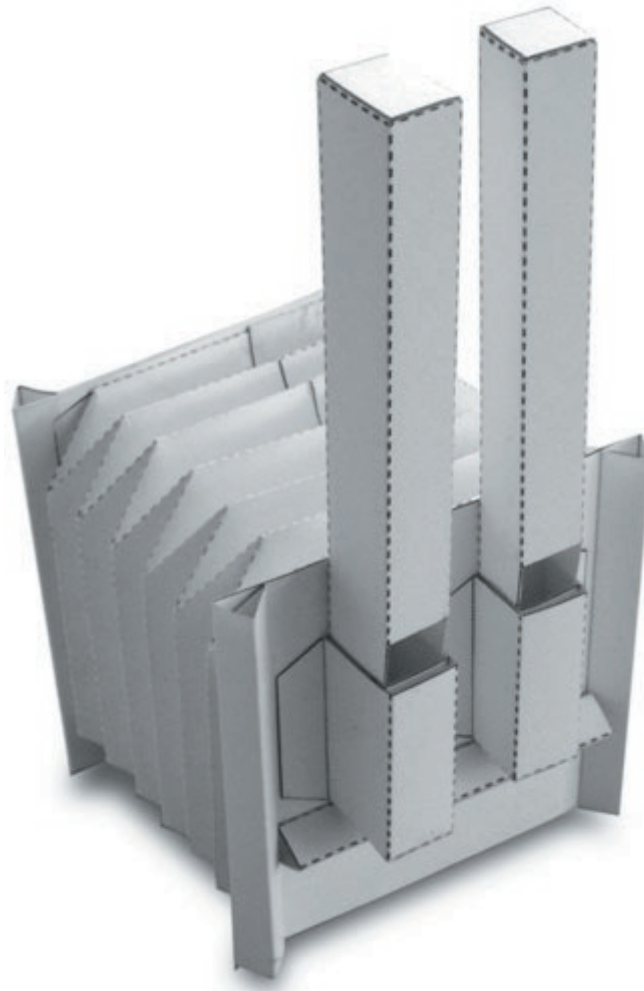

# Train Whistle

A cardboard engineering project exclusive to Flying Pig Newsletter subscribers



A fascinating cardboard engineering project. Pump the bellows and the two pipes make a realistic train whistle sound. Whoo whoo!

## **Instructions**

You will need a craft knife or other sharp knife, a pair of scissors, some glue and a glue spreader.

The best type of glue to use is PVA, white school glue.

Print the model parts onto thin card and the bellows onto paper.

Before cutting anything out, score along all the dotted lines and cut out any holes with a craft knife. Both these jobs are easier to do on full sheets of card.

Dashed lines are hill folds, dotted lines are valley folds. Cut along the solid lines. Grey areas show where to glue.

When making pipes accuracy is very important. Make sure that the parts are cut out and scored accurately and glued carefully. Make sure to block any air holes with a small amount of glue.

Both pipes are made the same way. Follow these instructions for both. Assemble the pipe tube as shown

Glue together the top cover as shown.

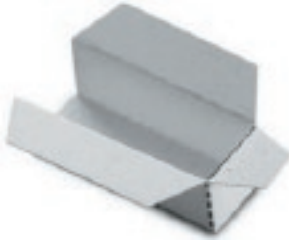

Glue the first cover into place, making sure to seal all the edges with glue.

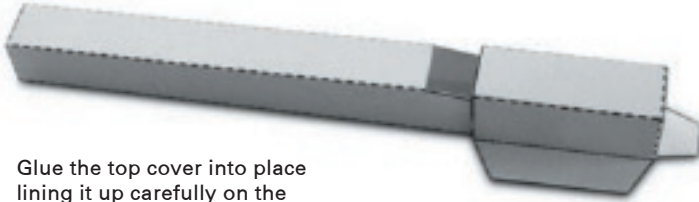

Glue the top cover into place lining it up carefully on the lower cover and taking care that it is straight and square.

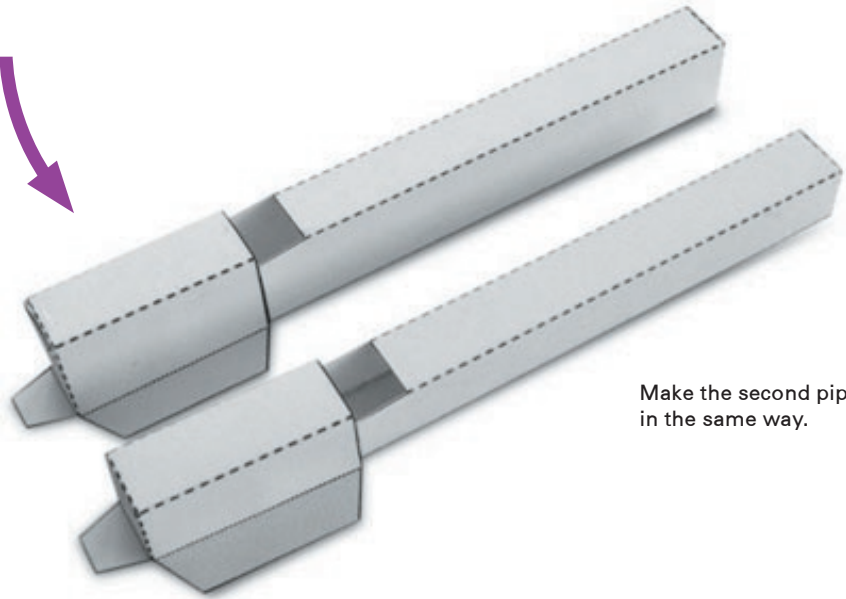

Make the second pipe in the same way.

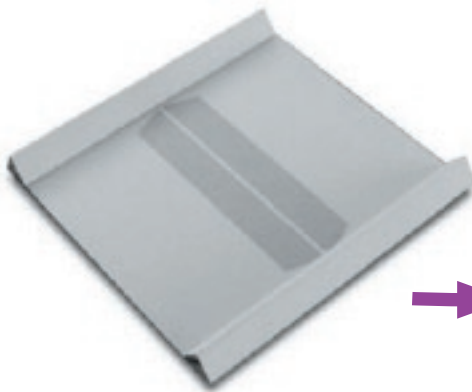

Glue together the base, top and stiffener as shown

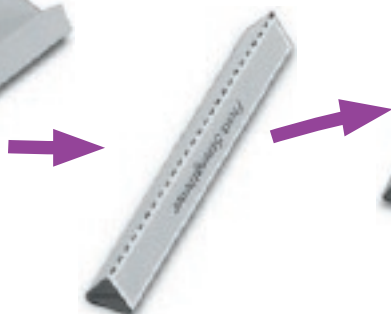

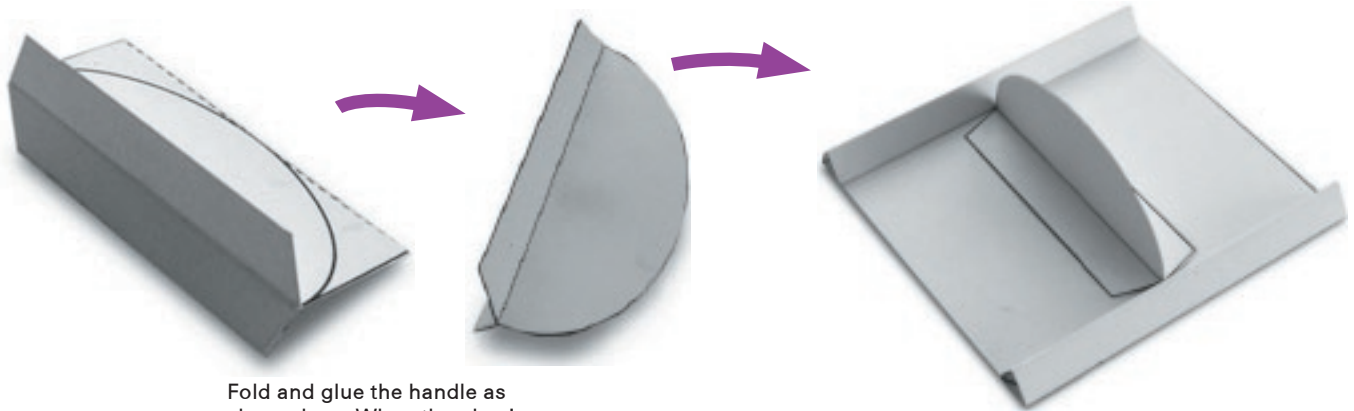

Fold and glue the handle as shown here. When the glue is dry cut along the black line to make a curved handle.

Glue the handle into place as shown.

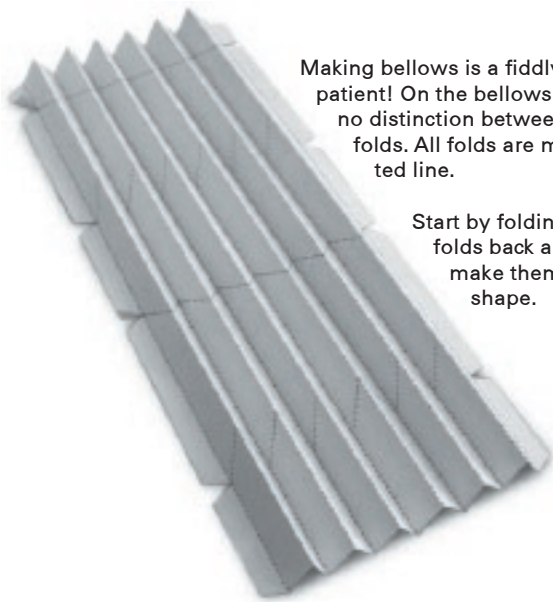

Making bellows is a fiddly operation, be patient! On the bellows sheet there is no distinction between hill and valley folds. All folds are marked with a dotted line.

Start by folding all the long folds back and forth then make them into this zig zag shape.

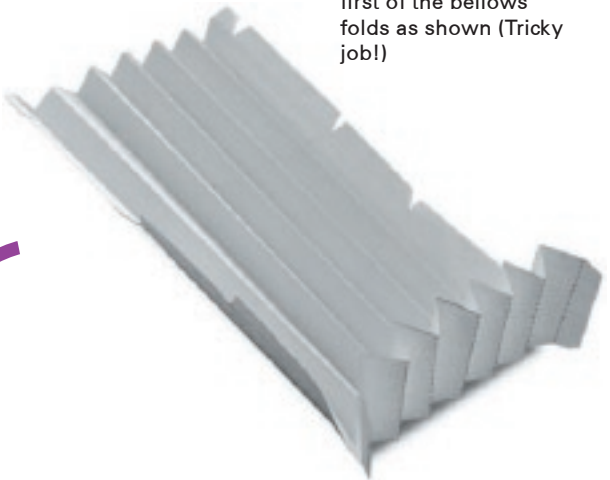

Carefully fold up the first of the bellows folds as shown (Tricky job!)



Continue folding each of the corners in turn. (It gets easier with practise.)

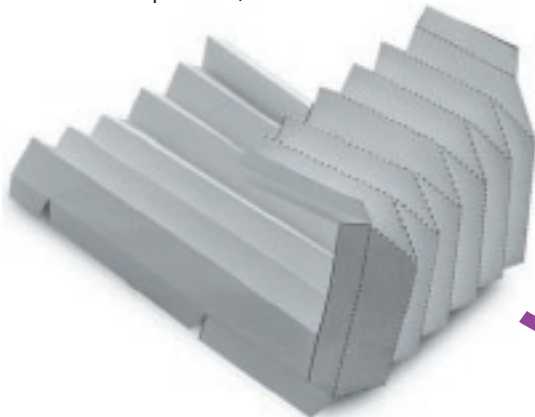

Glue the ends of the bellows into place being careful to line the end of the bellows up with the grey strip.



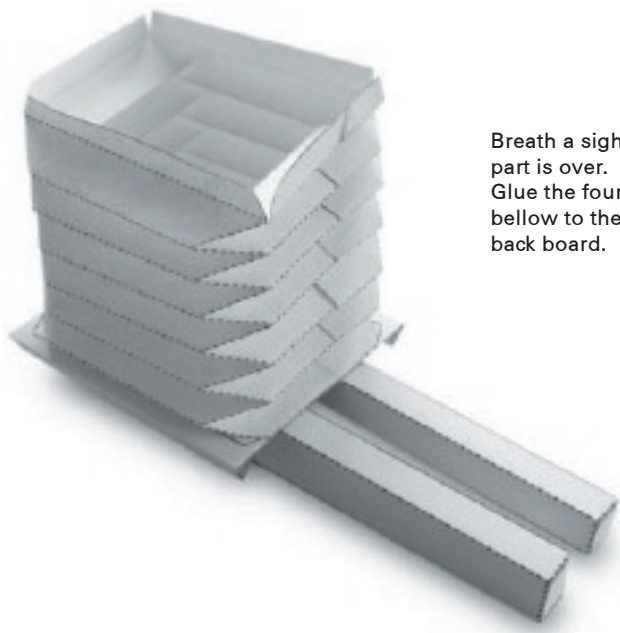

Breathe a sigh of relief. The hard part is over.  
Glue the four flaps on the bellow to the back of the pipes back board.

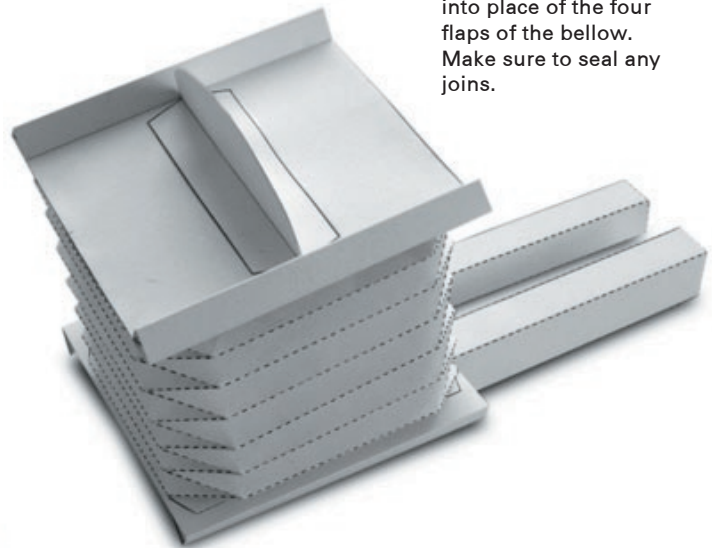

Glue the handle piece into place of the four flaps of the bellow. Make sure to seal any joins.

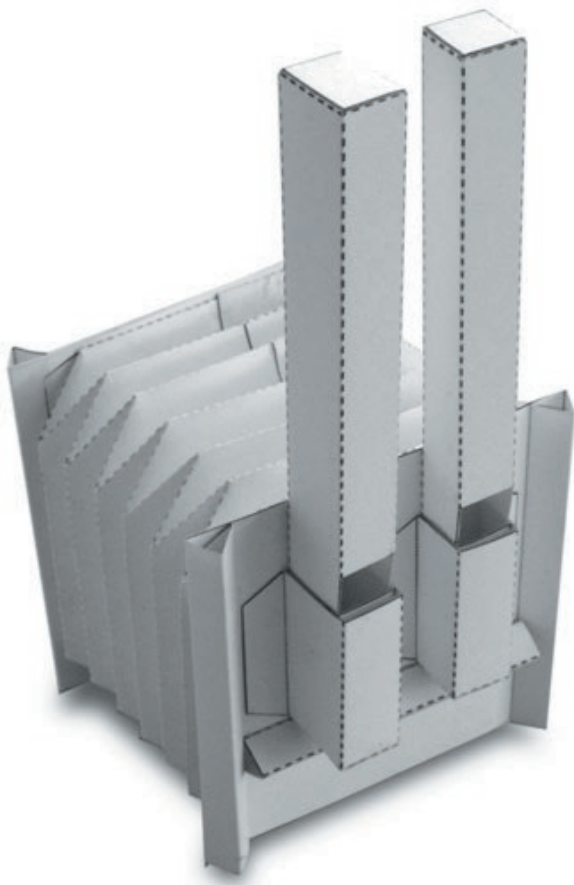

That's it!  
Once the glue is dry your train whistle should work!

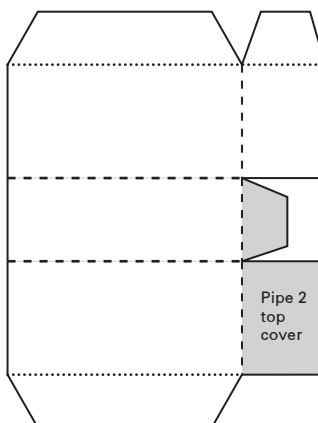
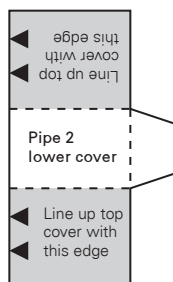
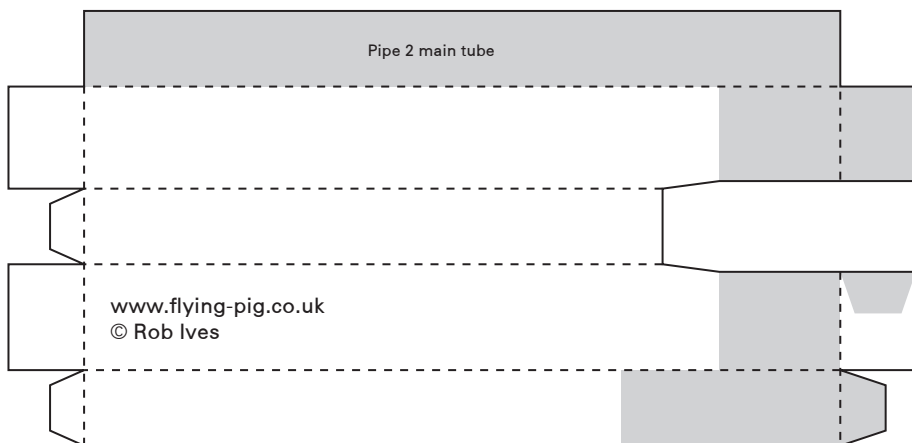
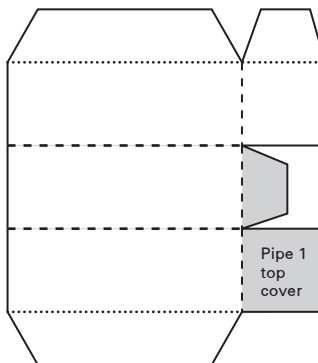
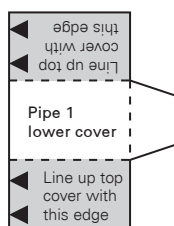
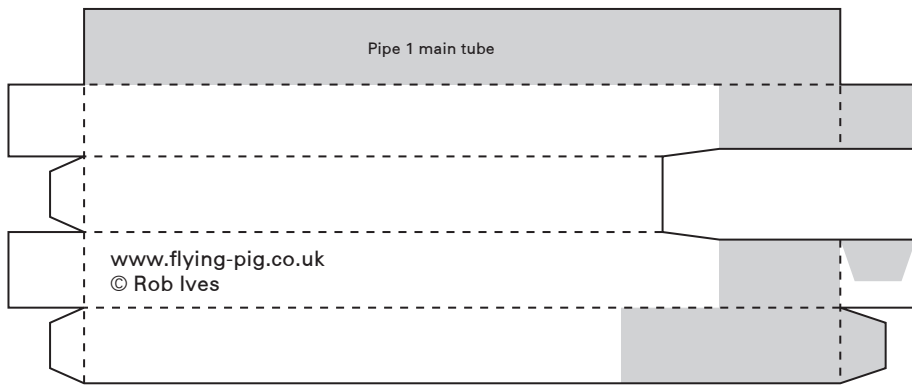

Print onto 80 gram paper

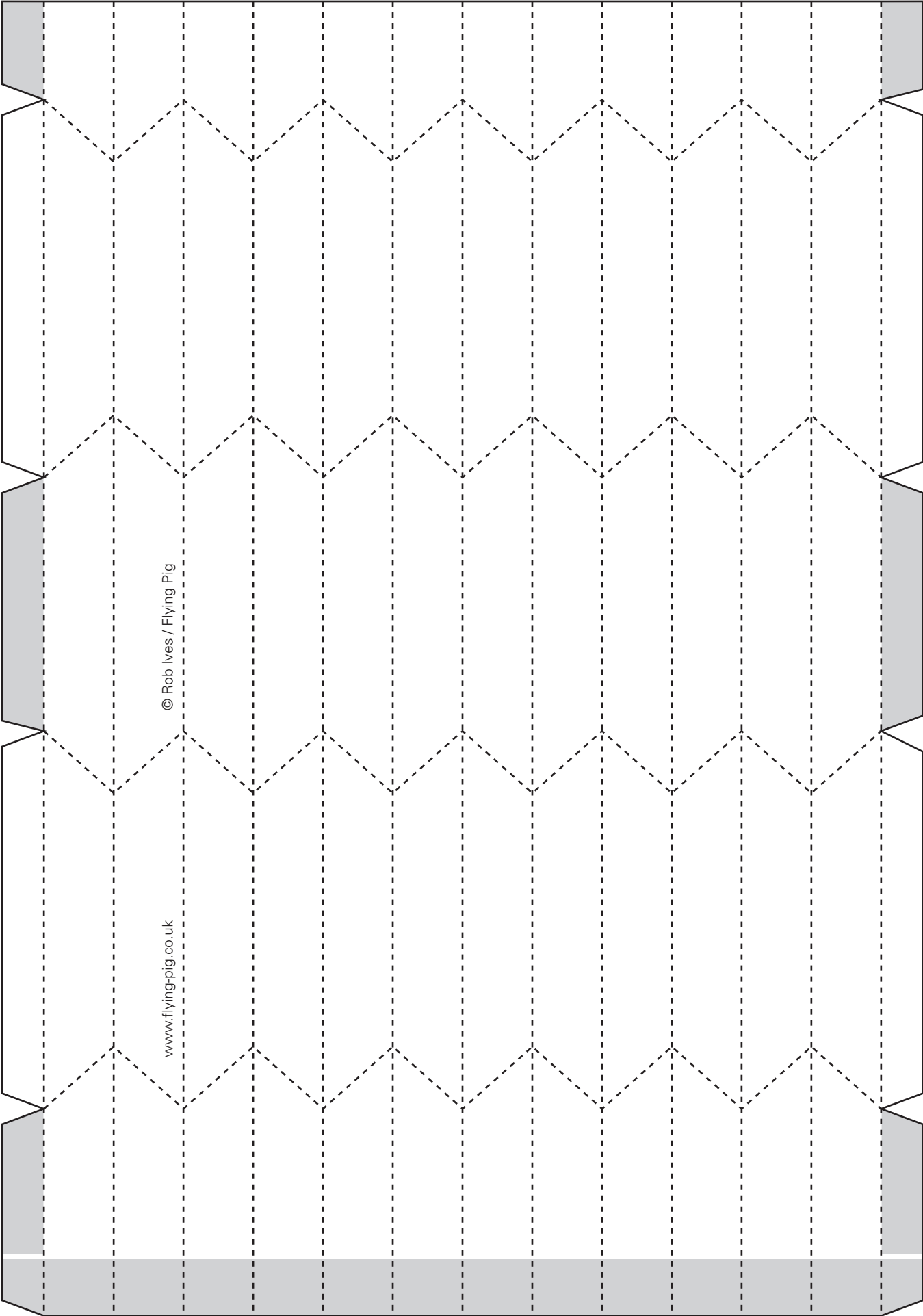

© Rob lves / Flying Pig

www.flying-pig.co.uk

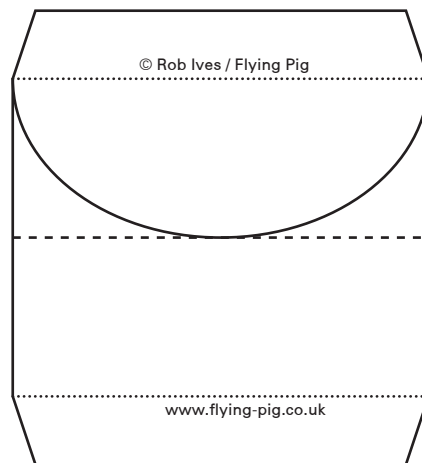
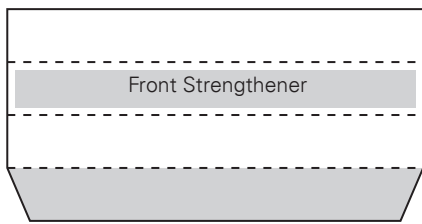
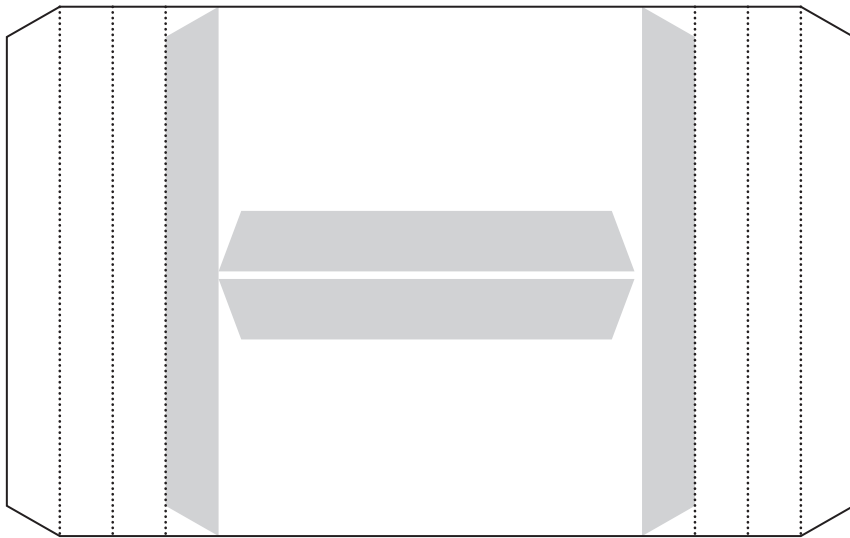
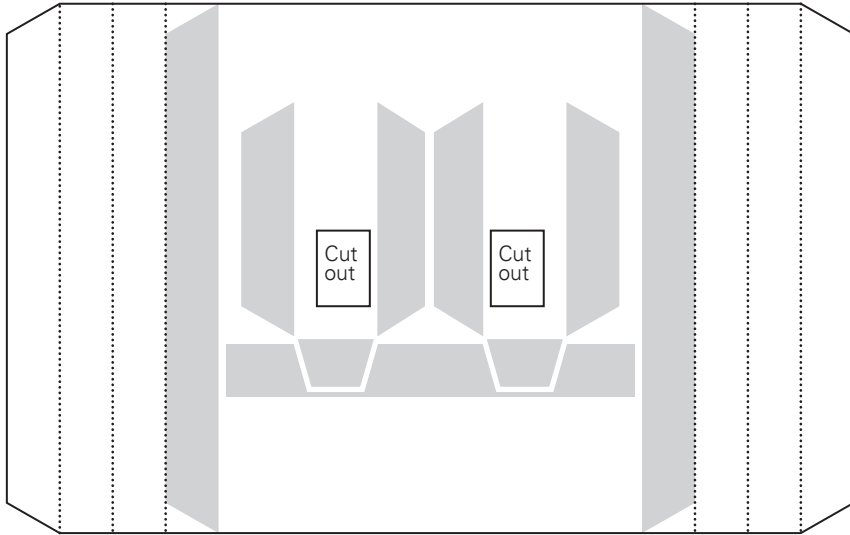

Parts page 3. Print onto thin card  
© Rob Ives / Flying Pig